

Applicable Standards :

DESIGN AND MANUFACTURE ON THE BASIS OF API 600、ASME B16.34

CONNECTION SIZE ON THE BASIS OF ASME B16.5、EN 1092

STRUCTURAL DIMENSION ON THE BASIS OF ASME B16.10、EN 588-1、DIN 3202

TEST AND INSPECTION ON THE BASIS OF ISO 5208、API 598、EN 12266

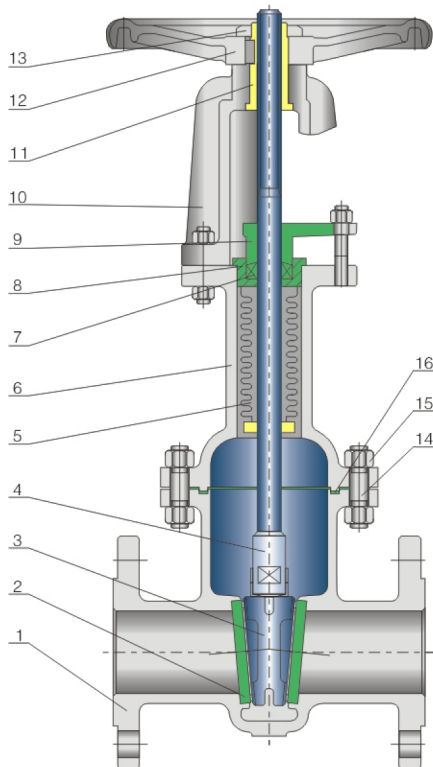

No	Part Name	No	Part Name
1	Body	9	Gland Flange
2	Seat	10	Yoke
3	Disc	11	Stem Nut
4	Stem	12	Handwheel
5	Bellows	13	Locknut
6	Bonnet	14	Bolt
7	Packings	15	Nut
8	Gland	16	Gasket

Product Features:

Bellows globe valve adopts sealed structure. In common valves, the packing seal of the stem ages fast and it is easy to leak, but this design totally eliminates these shortcomings. Apart from increasing the efficiency of materials and the safety of production equipment, it not only reduces maintenance costs and frequent maintenance of products but also provides a clean and safe working environment.

Double seal design (bellows and packings), if the bellows invalidates, the stem packings will prevent outside leaking. There are no fluid loss, but it reduces the energy loss and improves the equipment safety.

Longer service life, less maintenance and lower operating costs. Firm and durable seal design of bellows ensures the zero leakage of stem and provides more reliable performance and no maintenance. Quenched stem and surface nitridation with good performance of corrosion and friction resistance.

Excellent performance, graceful outline, and more visibility with position indicating of stem.

Materials of parts

Body	GS-C25/WCB/CF8M/CF8/CF3M/CF3/CD3MN
Seat	A105/F316/F304/F316L/F304L/F51
Disc	GS-C25/WCB/CF8M/CF8/CF3M/CF3/CD3MN
Bellows	304/316/316L/304L/S31803
Stem	F6a/F304/F316/F304L/F316L/F51/Monel
Bonnet	GS-C25/WCB/CF8M/CF8/CF3M/CF3/CD3MN
Bolt	B7M/B8M/L7M/B16M
Nut	2HM/8M/7M/4M
Gland	410/304/316/304L/316L
Stem Nut	C95200/D2/A536
Gasket	Flexible graphite+304/Flexible graphite+316
Packings	Flexible graphite

Materials can be altered according to the customers' requirement and valves' performances.

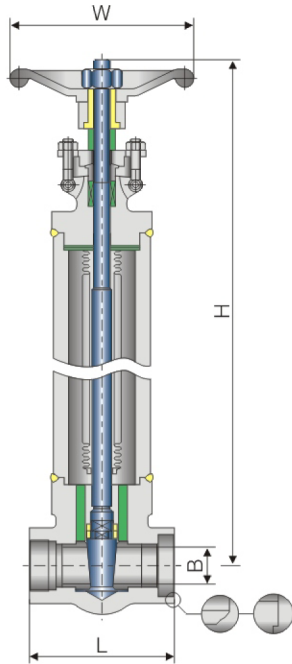

Structure of Forged steel valve(1/2"~2")

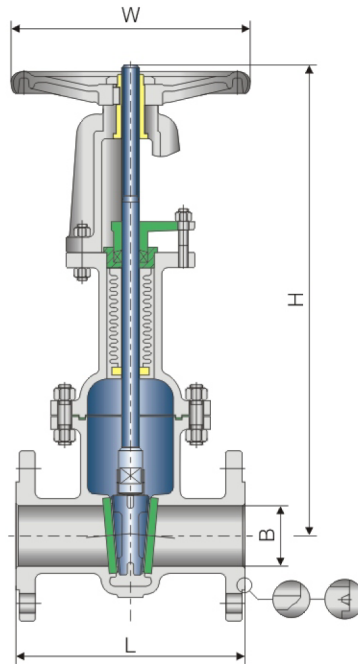

Structure of Cast steel valve(2"~16")

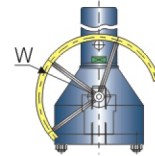

Main Dimensional Parameter

Class 150															
NPS	DN	L	B	H	W	WT	T	NPS	DN	L	B	H	W	WT	T
		mm	mm	mm	mm	Kg	N.M			mm	mm	mm	mm	Kg	N.M
1/2	15	79	10	200	100	7	13	3	80	203	76	444	250	53	36
3/4	20	92	13	212	120	8	17	4	100	229	102	492	280	68	65
1	25	111	18	248	125	9	22	6	150	267	152	585	300	142	88
1 1/4	32	120	24	263	160	13	25	8	200	292	201	677	350	188	155
1 1/2	40	120	29	290	160	20	27	10	250	330	252	766	400	255	205
2	50	178	51	375	200	29	31	12	★300	356	303	845	450	355	319
2 1/2	65	190	65	400	220	40	32	14	★350	381	337	903	500	420	369
Class 300															
NPS	DN	L	B	H	W	WT	T	NPS	DN	L	B	H	W	WT	T
		mm	mm	mm	mm	Kg	N.M			mm	mm	mm	mm	Kg	N.M
1/2	15	79	10	200	100	7	14	3	80	203	76	444	250	78	52
3/4	20	92	13	212	120	8	18	4	100	229	102	492	280	95	103
1	25	111	18	248	125	9	25	6	150	267	152	585	350	185	209
1 1/4	32	120	24	263	160	13	28	8	200	292	201	677	400	230	311
1 1/2	40	120	29	290	160	20	36	10	250	330	252	766	450	360	524
2	50	178	51	375	200	40	40	12	★300	356	303	845	500	480	706
2 1/2	65	190	65	400	220	56	45	14	★350	381	337	903	560	705	1031
Class 300															
NPS	DN	L	B	H	W	WT	T	NPS	DN	L	B	H	W	WT	T
		mm	mm	mm	mm	Kg	N.M			mm	mm	mm	mm	Kg	N.M
1/2	15	79	10	200	100	7	17	3	80	203	76	444	280	90	122
3/4	20	92	13	212	120	8	22	4	100	229	102	492	350	130	166
1	25	111	18	248	125	9	28	6	150	267	152	585	450	290	446
1 1/4	32	120	24	263	160	13	32	8	200	292	201	677	560	480	659
1 1/2	40	120	29	290	160	20	49	10	250	330	252	766	600	750	1168
2	50	178	51	375	250	52	56	★12	★300	356	303	845	460	920	1586
2 1/2	65	190	65	400	250	71	95	★14	★350	381	337	903	460	1120	2412

Instruction: ★ Means that it is operated by wormwheel.

Applicable Standards :

DESIGN & MANUFACTURE CONFORM WITH: EN 13709、ASME B16.34

CONNECTION DIMENSION CONFORMS WITH: EN 1092、ASME B16.5

INSPECTION & TEST CONFORMS WITH: EN 588-1、DIN 3202、ASME B16.10

MATERIAL CONFORMS WITH: EN 12266、ISO 5208、API 598

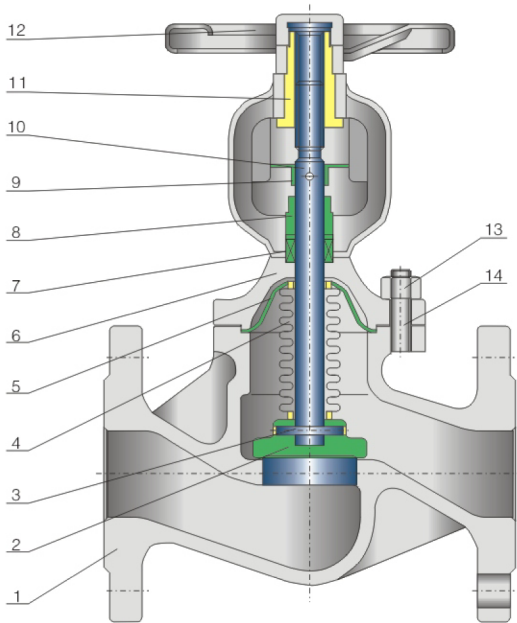

No	Part Name	No	Part Name
1	Body	8	Gland Bushing
2	Disc	9	Guide Member
3	Pin	10	Stem
4	Bellow	11	Stem Nut
5	Gasket	12	Handwheel
6	Bonnet	13	Nut
7	Packing	14	Bolt

Features and Application:

Bellows globe valve adopts sealed structure. In common valves, the packing seal of the stem ages fast and it is easy to leak, but this design totally eliminates these shortcomings. Apart from increasing the efficiency of materials and the safety of production equipment, it not only reduces maintenance costs and frequent maintenance of products but also provides a clean and safe working environment.

Double seal design (bellows and packings), if the bellows invalidates, the stem packings will prevent outside leaking. There are no fluid loss, but it reduces the energy loss and improves the equipment safety.

Longer service life, less maintenance and lower operating costs. Firm and durable seal design of bellows ensures the zero leakage of stem and provides more reliable performance and no maintenance.

Quenched stem and surface nitridation with good performance of corrosion and friction resistance.

Excellent performance, graceful outline, and more visibility with position indicating of stem.

Materials of parts

Body	GS-C25/WCB/CF8M/CF8/CF3M/CF3/CD3MN
Disc	A105/F316/F304/F316L/F304L/F51
Bellow	304/316/316L/304L/S31803
Stem	F6a/F304/F316/F304L/F316L/F51/Monel
Bonnet	GS-C25/WCB/CF8M/CF8/CF3M/CF3/CD3MN
Bolt	B7M/B8M/L7M/B16M
Nut	2HM/8M/7M/4M
Gland Bushing	410/304/316/304L/316L
Stem Nut	C95200/D2/A536
Gasket	Flexible graphite+304/Flexible graphite+316
Packing	Flexible graphite

Materials could be chosen according to customers' requirement & working condition.

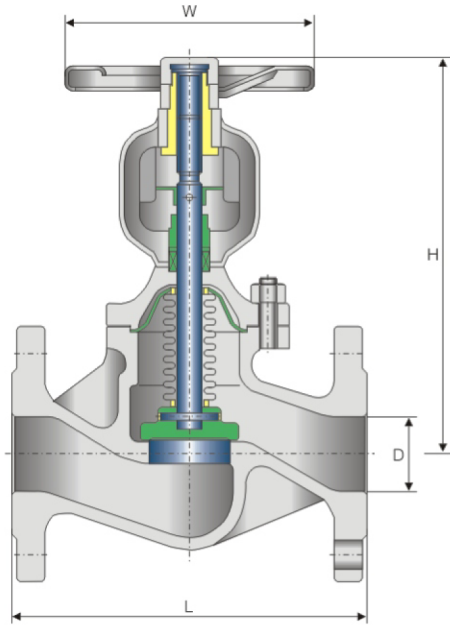

DIN Structure

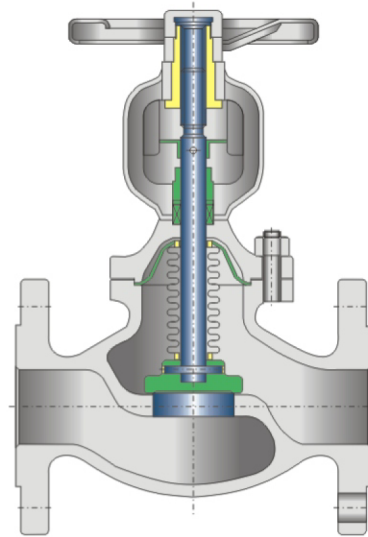

API Structure

Dimensional datas

PN 16															
NPS	DN	L	D	H	W	WT	T	NPS	DN	L	D	H	W	WT	T
		mm	mm	mm	mm	Kg	N.M			mm	mm	mm	mm	Kg	N.M
1/2	15	130	15	174	100	3.5	14	4	100	350	100	345	280	50	127
3/4	20	150	20	176	125	4	18	5	125	400	125	370	320	65	209
1	25	160	25	207	160	6	23	6	150	480	150	430	350	84	319
1 1/4	32	180	32	207	160	10	26	8	200	600	200	488	400	150	408
1 1/2	40	200	40	210	180	13	31	10	250	730	250	530	500	240	885
2	50	230	50	225	200	19	49	12	★300	850	300	600	460	360	1129
2 1/2	65	290	65	250	220	26	62	14	★350	980	350	700	600	490	1515
3	80	310	80	260	240	30	103	16	★400	1150	400	800	700	600	1805
PN 25															
NPS	DN	L	D	H	W	WT	T	NPS	DN	L	D	H	W	WT	T
		mm	mm	mm	mm	Kg	N.M			mm	mm	mm	mm	Kg	N.M
1/2	15	130	15	174	100	3.5	18	4	100	350	100	345	280	65	140
3/4	20	150	20	176	125	4	23	5	125	400	125	370	320	85	222
1	25	160	25	207	160	6	30	6	150	480	150	430	350	109	341
1 1/4	32	180	32	207	160	10	34	8	200	600	200	488	400	180	436
1 1/2	40	200	40	210	180	13	38	10	250	730	250	530	500	300	974
2	50	230	50	225	200	19	56	12	★300	850	300	600	460	450	1242
2 1/2	65	290	65	250	220	31	69	14	★350	980	350	700	600	613	1667
3	80	310	80	260	240	36	112	16	★400	1150	400	800	700	750	1986
PN 40															
NPS	DN	L	D	H	W	WT	T	NPS	DN	L	D	H	W	WT	T
		mm	mm	mm	mm	Kg	N.M			mm	mm	mm	mm	Kg	N.M
1/2	15	130	15	174	100	3.5	24	4	100	350	100	345	280	85	278
3/4	20	150	20	176	125	4	30	5	125	400	125	370	320	111	419
1	25	160	25	207	160	6	39	6	150	480	150	430	350	142	599
1 1/4	32	180	32	207	160	10	44	8	200	600	200	488	400	234	835
1 1/2	40	200	40	210	180	13	46	10	250	730	250	530	500	390	1266
2	50	230	50	225	200	19	78	12	★300	850	300	600	460	585	1615
2 1/2	65	290	65	250	220	40	92	14	★350	980	350	700	600	797	2167
3	80	310	80	260	240	47	179	16	★400	1150	400	800	700	975	2582

Note: ★ Manual control